

## TECHNICAL DATA

The short circuit at the point of installation must be considered for all switches. The max fuselink for prospective short circuit is shown in the following table.

### Cam Switch

Prospective Symm. Fault Current.	Switch rating A								
	40	63	125	200	315	400	630	800	1000
	Maximum permissible Fuse Size								
10 kA	50	63	125	250	315	400	630	2x400	2x400
25 kA	50	63	125	160	315	315	500	2x400	2x400
40 kA	40	63	125	160	315	315	400	500	500
<b>STR A rms. for 3s</b>	530	1100	1500	2000	3200	3800	5700	7500	7500

### Packet Switch

Switch rating	16	20	40	63	125	250	315	400	600
Prospective current 46 ka rms. max fuse	45	45	63	100	300	800	800	800	800
<b>STR A rms. for 1 sec</b>	400	400	1000	1200	3000	12500	12500	12500	20000

### Flat Pack Switches Changeover

	Max I sq t x 1000 (2)	STR 1sec (rms) KA, Icw (1)	Short Circuit making capacity (1)	Rated operational Ie AC22 (415V)	Rated operational Ie AC23 (415V)
200A	N/A	8	12 kA	200A	200A
250A	N/A	8	12 kA	250A	200A
315A	N/A	8	12 kA	315A	250A
400A	N/A	8	12 kA	400A	250A
500A	N/A	13	20 kA	500A	400A
630A	N/A	13	20 kA	630A	400A
800A	N/A	13	20 kA	800A	630A
1000A	N/A	25	32 kA	1000A	1000A
1250A	N/A	25	32 kA	1250A	1250A
1600A	N/A	35	42 kA	1600A	1000A
2000A	N/A	50	65 kA	2000A	1400A

### Flat Pack Switches Bypass

	Max I sq t x 1000 (2)	STR 1sec (rms) KA, Icw (1)	Short Circuit making capacity (1)	Rated operational Ie AC22 (415V)	Rated operational Ie AC23 (415V)
200A	497	10	14 kA	200A	200A
250A	1000	10	14 kA	250A	250A
315A	1000	10	14 kA	315A	315A
400A	1600	16	26 kA	400A	400A
630A	1600	16	26 kA	630A	630A
800A	4900	19	34 kA	800A	800A
1000A	N/A	35	42 kA	1000A	1000A
1250A	N/A	35	42 kA	1250A	1000A
1600A	N/A	35	42 kA	1600A	1000A

(1) Without limiting protective device. Short circuit maintained 50..100 ms (2) Maximum power dissipation (I<sup>2</sup>t) Icw Short circuit withstand current

## CABLE TERMINATION SIZES.

### Packet Switches

Rating	Terminal Screw	Torque NM	Max. Conn.
16A	M4	1.5	2.5 sq mm
25A	M4	1.5	2.5 sq mm
40A	M6	3	10 sq mm
63A	M6	3	25 sq mm
125A	M8	13	70 sq mm
200A	M12	45	240 sq mm
250A	M12	45	240 sq mm
315A	M12	45	240 sq mm
400A	M12	45	240 sq mm
600 A	M10 x 2	18	Flat cu. 30mm wide

### Cam Switches

Rating	Terminal Screw	Torque NM	Max. Conn.
20A	M3	0.2	1x4sq mm or 2x2.5sq mm
25A	M3	0.2	1x6sq mm or 2x4sq mm
40A	M4	1	1x10sq mm or 2x6sq mm
63A	M5	1	1x16sq mm or 2x10sq mm
125A/200A	M10	18	95sq mm
315A	M10	18	95sq mm
400A	M12	45	240sq mm
630A	M16	80	Cu 10x70 400sq mm
800A	M16	80	Cu 60x5sq mm
1000A	M16	80	Cu 3x50x5sq mm

### Flat Pack Switches Changeover

Rating	Terminal Screw	Torque NM	Max Conn
200A	M10	24	240 sq mm cu 2x5x30
250A	M10	24	"
315A	M10	24	"
400A	M10	24	"
500A	M12	45	2x240 cu 2x6x45
630A	M12	45	2 x240 sq mm cu 2x6x45
800A	M12	45	2x240 sq mm cu 2x6x45
1000A	M14	55	cu 2 x10 x60
1250A	M14	55	"
1600A	2XM14	55	cu 2x80x7
2000A	M12	45	cu 3x12x80

### Flat Pack Switches Bypass

Rating	Terminal Screw	Torque NM	Max Conn
200A	M8	13	185 sq mm cu 7x25
250A	M10	18	"
315A	M10	18	"
400A	M10	24	240 sq mm cu 6x40
630A	M10	24	240 sq mm cu 2x5x40
800A	M14	45	2x240 sq mm cu 2x10x50
1000A	M16	80	cu 2x80x7
1250A	M16	80	"
1600A	2XM14	55	"



**santon**

www.santonswitchgear.com

Santon Holland bv, Rotterdam  
Tel: +31(0)10 283 26 00 • Fax: +31(0)10 429 45 46  
E-mail: info@santonswitchgear.com  
Internet: www.santonswitchgear.com  
EN-ISO 9001

Santon Switchgear Ltd, Newport  
Tel.: +44(0)1633-854111 • Fax: +44(0)1633-854999  
E-mail: sales@santonswitchgear.co.uk  
Internet: www.santonswitchgear.com  
EN-ISO 9000:2000

Santon GmbH, Nettetal  
Tel: 0180/118 40 88 • Fax: 0180/118 41 99  
E-Mail: info@santonswitchgear.com  
Internet: www.santonswitchgear.com  
EN-ISO 9001

Santon Spain, Madrid  
Tel: +34 902027175 • Fax: +34 902027295  
E-Mail: info@santonswitchgear.com  
Internet: www.santonswitchgear.com  
EN-ISO 9001

# Changeover and Bypass Switches





# CHANGEOVER AND BYPASS SWITCHES

Santon produce 3 ranges of manual changeover switches, the Packet, Cam and Flat pack types. The Packet and Cam can be provided with or without off position and are available enclosed or as an open type for mounting in customers equipment, i.e. control panels etc.

## PACKET SWITCH CHANGEOVER AND BYPASS SWITCHES

Santon rotary packet switches have a fine tradition and have been manufactured for over 80 years. They are capable of onload switching and have manually dependent mechanisms fitted as standard up to and including 125A rating, however, manually independent mechanisms can be fitted if requested. Above 125A rating manually independent mechanisms are standard. Rotary switch contacts have silver surfaces and are of the wiping blade type resulting in low resistance and self cleaning. The moving contact consists of two parallel blades to give maximum pinch performance under short-circuit conditions.

Above 600A rating certain bypass arrangements consist of two separate switches suitably interlocked with figure locks. Santon packet switches comply with EN-IEC60947-3.

## CAM OPERATED CHANGEOVER AND BYPASS SWITCHES

Santon rotary cam switches are manufactured by modern production processes and comply with the latest European standards. They have manually dependent spring operated mechanisms and the housing cells for the contacts are moulded in a thermosetting melamine with excellent resistance to arc and tracking. The insulation voltage for cam switches is 660v. All ratings are capable of on load switching but the 1000A has a load breaking facility only. The butt contacts are all double break

'anti-weld' silver alloy which provide an exceptionally long mechanical life. Above 315A the contacts are paralleled to provide the higher ratings. The maximum number of contact cells driven from a pair of mechanisms is 12. Switches requiring above 12 cells are ganged together in groups of 2, 3 or 4 stacks, driven from a single handle through a precision engineered steel gear drive mechanism. Santon cam switches comply with EN-IEC60947-3.

## FLAT PACK CHANGEOVER AND BYPASS SWITCHES

Santon flat pack switches are a combination of in-line interlocked switches which have manually independent mechanisms and 3 positions; 1.0.2. and BYPASS-OFF-NORMAL. The contacts are double break wiping action clip and blade type. Terminations are the in line arrangement for ease of connection.

The changeover and bypass links are included with the switch thus reducing the number of cables or switch connections. Santon flat pack switches comply with EN-IEC60947-3.



125A Packet switch changeover



200A Flat pack changeover. OCCFX4-200



20A Cam switch E(O)CX4.20 changeover

#### TYPES

Packet switch	Designated - RX	} Prefix 0 if Off position required.
Cam switch	Designated - CX	
Flat pack type	Designated - OFX & OCCFX	

e.g. With off, RX becomes ORX. CX becomes OCX. The Flatpack is only available with off.

As standard the packet switch and cam switch types are available in 2 and 4 pole arrangements. Other combinations of poles and ratings can be produced on application. Flat pack switches are 4 pole form as standard.

Changeover switches are suitable for 415v AC, switches with DC voltages are available on request.

Order reference Rating AMPS AC22 415V	Rotary cam Switch 2 Pole	Rotary cam Switch 4 Pole	Rotary Packet Switch 2 Pole	Rotary Packet Switch 4 Pole	Flat Pack Switch 4 Pole
16			RX2.16	RX4.16	
20	CX2.20	CX4.20			
25	CX2.25	CX4.25	RX2.25	RX4.25	
40	CX2.40	CX4.40	RX2.40	RX4.40	
63	CX2.63	CX4.63	RX2.63	RX4.63	
125	CX2.125	CX4.125	RX2.125	RX4.125	
200	CX2.200	CX4.200	RX2.200	RX4.200	OCCFX4.200
250					OCCFX4.250
315	CX2.315	CX4.315	RX2.315	RX4.315	OCCFX4.315
400	CX2.400	CX4.400	RX2.400	RX4.400	OCCFX4.400
500					OCCFX4.500
600	CX2.600	CX4.600	RX2.600	RX4.600	OCCFX4.600
800	CX2.800	CX4.800			OCCFX4.800
1000	CX2.1000	CX4.1000			OCCFX4.1000
1250					OCCFX4.1250
1600					OFX4.1600
2000					OFX4.2000

If a surface mounted (enclosed) changeover switch is required, Prefix E is to be added. E.g. EORX4.125

## TYPICAL TERMINAL MARKINGS

### Packet switch

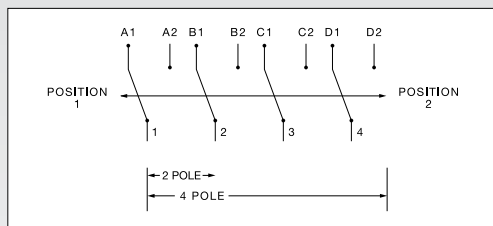

### Cam switch

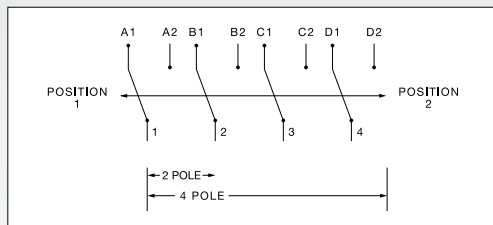

NOTE: Some CAM switches may have terminal markings as the packet switch.

## OVERALL DIMENSIONS OF SWITCHES EXCLUDING HANDLE.

### Cam Switches (4 pole) - Panel mounted with direct handle

Switch Reference	H x W x D (Volume only)
CX4.20	48 x 48 x 82
CX4.25	61 x 61 x 88
CX4.40	61 x 61 x 82
CX4.63	84 x 84 x 111
CX4.125	145 x 126 x 192
CX4.200	145 x 126 x 192
CX4.315	145 x 126 x 192
CX4.400	170 x 126 x 314
CX4.630	190 x 126 x 432

### Packet Switches (4 pole) - Panel mounted with direct handle

Switch Reference	H x W x D (Volume only)
RX4.16	74x 70 x 89
RX4.25	74 x 70 x 89
RX4.40	105 x 114 x 150
RX4.63	105 x 116 x 120
RX4.125	105 x 116 x 180
RX4.200	216 x 216 x 290
RX4.315	216 x 216 x 290
RX4.400	216 x 216 x 290
RX4.600	216 x 216 x 463

### Flat Pack Switches (4 pole) - Base mounted with door interlocking handle

Switch Reference	H x W x D (Volume only)
OCCFX4.200	216 x 235 x 200
OCCFX4.250	216 x 235 x 200
OCCFX4.315	216 x 235 x 200
OCCFX4.400	216 x 235 x 200
OCCFX4.500	312 x 424 x 250
OCCFX4.630	312 x 424 x 250
OCCFX4.800	312 x 424 x 250
OCCFX4.1000	419 x 424 x 250
OCCFX4.1250	419 x 424 x 250
OFX4.1600	441 x 532 x 415
OFX4.2000	550 x 500 x 800

## APPROX DIMENSIONS FOR ENCLOSED CHANGEOVER SWITCHES. THERMOPLASTIC IP65, SHEET STEEL IP54

### Cam Switches (2 + 4 Pole)

Switch Reference	Enclosure	H x W x D
E(O)CX2.20	Thermoplastic	90 x 90 x 100
E(O)CX4.20	"	90 x 90 x 100
E(O)CX2.25	"	90 x 90 x 100
E(O)CX4.25	"	90 x 90 x 100
E(O)CX2.40	"	176 x 125 x 85
E(O)CX4.40	"	176 x 125 x 85
E(O)CX2.63	"	176 x 125 x 85
E(O)CX4.63	"	176 x 125 x 120
E(O)CX2.125	Sheet Steel	400 x 300 x 300
E(O)CX4.125	"	400 x 300 x 300
E(O)CX2.200	"	400 x 300 x 300
E(O)CX4.200	"	400 x 300 x 300
E(O)CX2.315	"	600 x 400 x 400
E(O)CX4.315	"	600 x 400 x 400
E(O)CX2.400	"	600 x 400 x 400
E(O)CX4.400	"	600 x 400 x 400
E(O)CX2.630	"	600 x 600 x 600
E(O)CX4.630	"	600 x 600 x 600

### Packet Switches (2 + 4 Pole)

Switch Reference	Enclosure	H x W x D
E(O)RX2.16	Sheet Steel	112 x 112 x 81
E(O)RX4.16	"	164 x 164 x 106
E(O)RX2.25	"	164 x 164 x 106
E(O)RX4.25	"	164 x 164 x 157
E(O)RX2.40	"	164 x 164 x 106
E(O)RX4.40	"	164 x 164 x 157
E(O)RX2.63	"	300 x 300 x 150
E(O)RX4.63	"	300 x 300 x 150
E(O)RX2.125	"	400 x 300 x 300
E(O)RX4.125	"	400 x 300 x 300
E(O)RX2.200	"	600 x 400 x 400
E(O)RX4.200	"	600 x 400 x 400
E(O)RX2.315	"	600 x 400 x 400
E(O)RX4.315	"	600 x 400 x 400
E(O)RX4.400	"	600 x 400 x 400
E(O)RX4.600	"	600 x 600 x 600

### Flat Pack Switches (4 Pole)

Switch Reference	Enclosure	H x W x D
EOCCFX4.200	Sheet Steel	600 x 400 x 200
EOCCFX4.250	"	600 x 400 x 200
EOCCFX4.315	"	600 x 400 x 200
EOCCFX4.400	"	600 x 400 x 200
EOCCFX4.500	"	700 x 500 x 200
EOCCFX4.630	"	700 x 500 x 200
EOCCFX4.800	"	1000 x 600 x 200
EOCCFX4.1000	"	1000 x 600 x 300
EOCCFX4.1250	"	1150 x 600 x 300
EOFX4.1600	"	1400 x 800 x 500
EOFX4.2000	"	2000 x 1000 x 800

# BYPASS SWITCHES

The majority of installations which have a mains and a standby supply invariably incorporate an automatic changeover contactor to feed either supply to the load.

Periodic examination and maintenance of the changeover contactor is vital to ensure that it will function correctly in the event of a mains failure.



*1000A Flatpack Bypass Switch*

To ensure that maintenance can be carried out in safety the changeover contactor must be isolated.

The Santon Bypass switch enables isolation from the mains supply and/or the standby supply whilst ensuring that the supply is fed to the load.

All standard Bypass switches are 4 pole and are suitable for 415/440v 3ph & SN supply.

## TYPE 1. NORMAL BYPASS.

### NORMAL POSITION.

Mains supply is fed to the input of the changeover contactor. The common of the changeover contactor feeds the load.

**Note:** the stand-by or generator must be connected directly to the changeover contactor.

### BYPASS POSITION.

The load is fed directly from the main supply, the changeover contactor is isolated from the main supply and the load.

**Note:** The stand-by supply or generator remains connected to the changeover contactor.

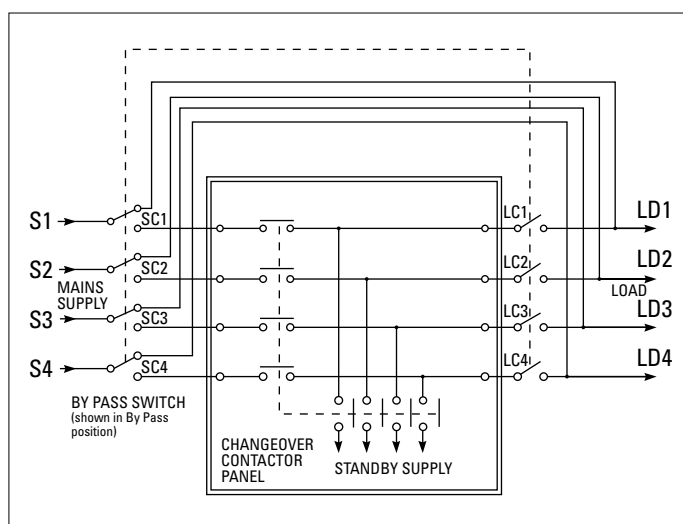

NORMAL		By Pass
S1 - SC1, LD1 - LC1	S2 - SC2, LD2 - LC2	S1 - LD1, S2 - LD2
S3 - SC3, LD3 - LC3	S4 - SC4, LD4 - LC4	S3 - LD3, S4 - LD4

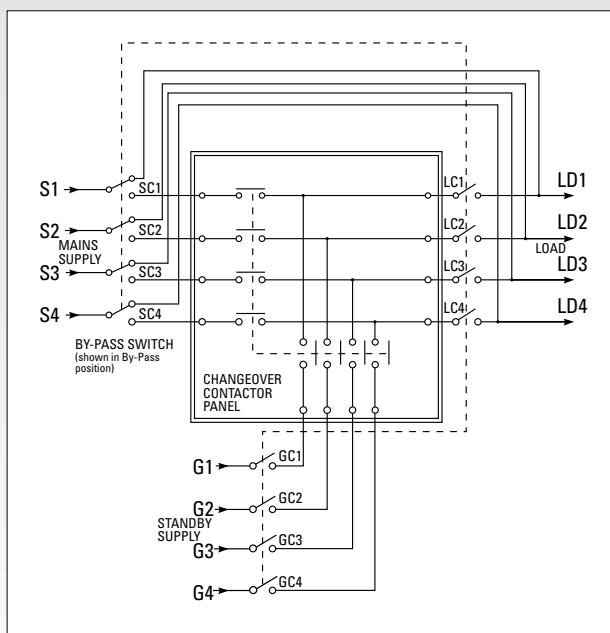

NORMAL	Bypass
S1 - SC1, G1 - GC1, LD1 - LC1	S1 - LD1, S2 - LD2
S2 - SC2, G2 - GC2, LD2 - LC2	S3 - LD3, S4 - LD4
S3 - SC3, G3 - GC3, LD3 - LC3	
S4 - SC4, G4 - GC4, LD4 - LC4	

## TYPE 2. NORMAL - BYPASS.

### NORMAL POSITION.

Main supply is fed to the input of the changeover contactor. The common of the changeover contactor feeds the load. Stand-by or generator supply is fed to the input of the changeover contactor.

### BYPASS POSITION.

The load is fed directly from the main supply. The changeover contactor is isolated from the main and stand-by supplies as well as the load.



400A Packet switch Bypass type 3

# BYPASS SWITCHES

## TYPE 3. STANDBY BYPASS - NORMAL - MAINS BYPASS.

### MAINS BYPASS POSITION.

The load is fed directly from the main supply. The changeover contactor is isolated from the main and stand-by supplies as well as the load.

### NORMAL POSITION.

Main supply is fed to the input of the changeover contactor. The common of the changeover contactor feeds the load. Stand-by or generator supply is fed to the input of the changeover contactor.

### STAND-BY BYPASS POSITION.

The load is fed directly from the stand-by supply. The changeover contactor is isolated from the main and stand-by supplies as well as the load.

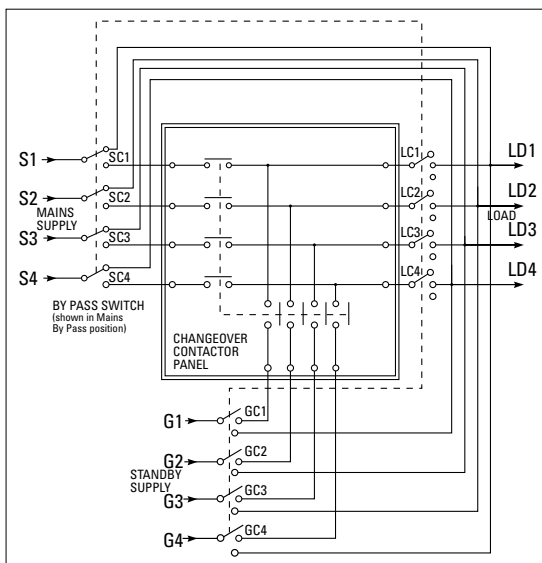

MAIN Bypass	NORMAL	S'BY Bypass
S1 - LD1	S1 - SC1, LD1 - LC1, G1 - GC1	G1 - LD1
S2 - LD2	S2 - SC2, LD2 - LC2, G2 - GC2	G2 - LD2
S3 - LD3	S3 - SC3, LD3 - LC3, G3 - GC3	G3 - LD3
S4 - LD4	S4 - SC4, LD4 - LC4, G4 - GC4	G4 - LD4

**BYPASS SWITCHES STANDARD ORDER REFERENCES.****(4 POLE – PREFIX 'O' FOR 'OFF' POSITION ).****OPTIONS ON STANDARD BYPASS SWITCH**

1. *An Off position can be provided on packet switch and cam switch-type 1 and 2 bypass switches if required. An Off position can be provided on the type 3 packet switch only.*
2. *Auxiliary contacts can be provided to suit individual requirements.*
3. *1,2 or 3 pole alternatives are available.*
4. *Door sequenced/interlock handles can be provided for switches mounted behind hinged doors.*
5. *Castell/Fortress interlocking is available to suit specific requirements.*
6. *Enclosed bypass switches are available upon request.*
7. *Make Before Break contacts are available upon request.*

T Y P E 1			
Rating AC22	Cam	Packet	Flatpack
40A	CB1.4.40	RB1.4.40	
63A	CB1.4.63	RB1.4.63	
125A	CB1.4.125	RB1.4.125	
200A	CB1.4.200		OFB1.4.200
250A		RB1.4.250	OFB1.4.250
315A	CB1.4.315		OFB1.4.315
400A	CB1.4.400	RB1.4.400	OFB1.4.400
600A	CB1.4.600.2	RB1.4.600	OFB1.4.600
800A	CB1.4.800.4		OFB1.4.800
1000A			OFB1.4.1000
1250A			OFB1.4.1250
1600A			OFB1.4.1600

T Y P E 2		
Rating	Cam	Packet
40A	CB2.4.40	RB2.4.40
63A	CB2.4.63	RB2.4.63
125A	CB2.4.125	RB2.4.125
200A	CB2.4.200	
250A		RB2.4.250
315A	CB2.4.315	
400A	CB2.4.400.2	RB2.4.400
600A	CB2.4.600.4	
800A	CB2.4.800.4	

T Y P E 3		
Rating	Cam	Packet
40A	CB3.4.40	RB3.4.40
63A	CB3.4.63	RB3.4.63
125A	CB3.4.125	RB3.4.125
200A	CB3.4.200	
250A		RB3.4.250
315A	CB3.4.315	
400A	CB3.4.400.4	RB3.4.400
600A	CB3.4.600.4	
800A	CB3.4.800.4	

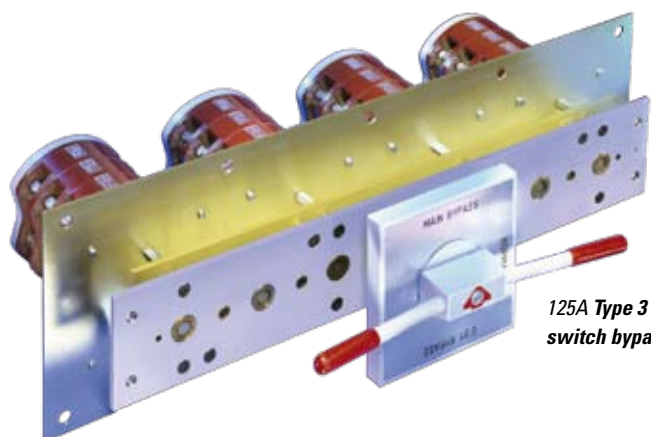
**Note: Off position is not available for CB3 type**

**125A Type 3 cam  
switch bypass, 4 gang**

# 'UPS' BYPASS SWITCHES

## GENERAL

Bypass switches enable the load to be fed directly from the mains supply in the bypass position, whilst the UPS is disconnected. A test position is provided such that the UPS unit is energised when bypassed so tests can be made.

UPS switches may be single pole & SN or TP & SN. Contacts used on UPS bypass switches are make before break, so as not to cause an interruption to the supply during switching. An aux contact is made in between the 'Normal' and 'Test' position. Other combination of auxiliaries can be supplied and are available upon request.

Note: Bypass arrangements using 3 individual isolater switches are also available, details on request

63A Single phase & SN H6P-RA8

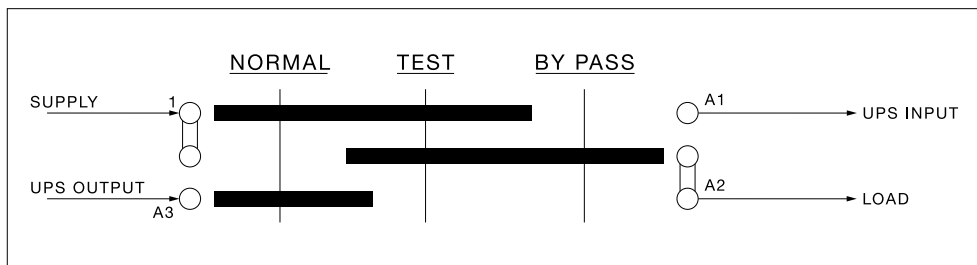

Standard Diagram for  
**UPS Bypass Switch** with  
Test Position.

CONTACTS	
NORMAL POSITION	1 - A1, A3 - A2 (SINGLE POLE)
TEST	1 - A1 - A2
BYPASS	1 - A2

### 3 position UPS Normal/Test/Bypass switches

	Single Phase & SN	Three Phase & SN
20A	H1P-RA8	H1P-TEO
32A	H3P-RA8	H3P-TEO
40A	H4P-RA8	H4P-TEO
63A	H6P-RA8	H6P-TEO
80A	N80P-RA8	N80P-TEO
125A	H12C-RA8	H12C-TEO
200A	NC2C-RA8	NC2C-TMO
315A	G3C-RA8	G3C-TMO
400A	NC4C-RA8	NC4C-TMO

630A and above on request

### 2 position UPS Normal/Bypass switches

	Single Phase & SN	Three Phase & SN
20A	CB1.2.20/MBB	CB1.4.20/MBB
32A	CB1.2.32/MBB	CB1.4.32/MBB
40A	CB1.2.40/MBB	CB1.4.40/MBB
63A	CB1.2.63/MBB	CB1.4.63/MBB
80A	CB1.2.80/MBB	CB1.4.80/MBB
125A	CB1.2.125/MBB	CB1.4.125/MBB
200A	CB1.2.200/MBB	CB1.4.200/MBB
315A	CB1.2.315/MBB	CB1.4.315/MBB
400A	CB1.2.400/MBB	CB1.4.400/MBB

## OVERALL DIMENSIONS OF BYPASS SWITCH EXCLUDING HANDLE.

**Note:** If required fitted into a sheet steel enclosure prefix  
the reference with 'E' i.e.ECB1.4.40

### Cam Switches

Order Reference	H x W x D (Open)	H x W x D (Enclosed)
CB1.4.40	65 x 65 x 115	300 x 200 x 200
CB1.4.63	65 x 65 x 146	300 x 200 x 200
CB1.4.125	145 x 126 x 252	400 x 300 x 300
CB1.4.200	145 x 126 x 252	400 x 300 x 300
CB1.4.315	145 x 126 x 252	600 x 400 x 400
CB1.4.400	170 x 126 x 432	600 x 400 x 400
CB1.4.630.2	260 x 340 x 430	600 x 400 x 450
CB1.4.800.4	260 x 675 x 340	1000 x 800 x 600
CB2.4.40	65 x 65 x 145	300 x 200 x 200
CB2.4.63	65 x 65 x 183	400 x 300 x 300
CB2.4.125	145 x 126 x 314	600 x 400 x 400
CB2.4.200	145 x 126 x 314	460 x 460 x 460
CB2.4.315	145 x 126 x 314	600 x 600 x 600
CB2.4.400.2	210 x 340 x 400	600 x 600 x 600
CB2.4.630.4	260 x 648 x 340	1000 x 800 x 600
CB2.4.800.4	260 x 648 x 400	1000 x 800 x 600
CB3.4.40	65 x 65 x 170	300 x 200 x 200
CB3.4.63	65 x 65 x 220	390 x 390 x 268
CB3.4.125	145 x 126 x 373	460 x 460 x 460
CB3.4.200	145 x 126 x 373	460 x 460 x 460
CB3.4.315	145 x 126 x 373	600 x 600 x 600
CB3.4.400.4	210 x 648 x 340	1000 x 800 x 600
CB3.4.630.4	260 x 648 x 430	1000 x 800 x 600
CB3.4.800.4	260 x 648 x 520	1000 x 800 x 600

### Packet Switches

Order Reference	H x W x D (Open)	H x W x D (Enclosed)
RB1.4.40	120 x 120 x 160	300 x 300 x 200
RB1.4.63	125 x 125 x 160	300 x 300 x 200
RB1.4.125	125 x 125 x 240	400 x 300 x 300
RB1.4.250	230 x 230 x 330	460 x 460 x 460
RB1.4.400	230 x 230 x 330	600 x 600 x 600
RB1.4.600	250 x 250 x 600	1000 x 800 x 600
RB2.4.40	120 x 120 x 190	214 x 214 x 268
RB2.4.63	125 x 125 x 190	400 x 300 x 300
RB2.4.125	125 x 125 x 315	600 x 400 x 400
RB2.4.250	230 x 230 x 505	600 x 600 x 600
RB2.4.400	230 x 230 x 505	600 x 600 x 600
RB3.4.40	120 x 120 x 230	214 x 214 x 268
RB3.4.63	125 x 125 x 230	400 x 300 x 300
RB3.4.125	155 x 125 x 405	460 x 460 x 460
RB3.4.250	230 x 230 x 505	600 x 600 x 600
RB3.4.400	230 x 230 x 505	600 x 600 x 600

### Flat Pack Switches

Order Reference	H x W x D (Open)	H x W x D (Enclosed)
OFB1.4.200	190 x 298 x 400	800 x 500 x 450
OFB1.4.250	190 x 298 x 400	800 x 500 x 450
OFB1.4.315	190 x 298 x 400	800 x 500 x 450
OFB1.4.400	280 x 373 x 460	1000 x 600 x 550
OFB1.4.630	280 x 373 x 460	1000 x 600 x 550
OFB1.4.800	300 x 422 x 487	1000 x 600 x 550
OFB1.4.1000	391 x 532 x 580	1400 x 1000 x 600
OFB1.4.1250	391 x 532 x 580	1400 x 1000 x 600
OFB1.4.1600	451 x 532 x 580	1400 x 1000 x 600