



THE SANTON EMERGENCY SWITCH

FIREFIGHTER SAFETY

WITH PHOTOVOLTAIC INSTALLATIONS



santon

superior switch solutions



THE SANTON EMERGENCY SWITCH

FIREFIGHTER SAFETY
WITH PHOTOVOLTAIC INSTALLATIONS



THESE DAYS FIREFIGHTERS HAVE TO DEAL WITH THREATS BEYOND JUST FIRE ITSELF. IN RECENT YEARS THE NUMBER OF PHOTOVOLTAIC INSTALLATIONS IN BOTH RESIDENTIAL AND NON-RESIDENTIAL BUILDINGS HAS INCREASED ENORMOUSLY THROUGHOUT THE WORLD. AND THAT NUMBER IS EXPECTED TO CONTINUE TO GROW IN THE COMING YEARS.

Photovoltaic installations generate direct current (DC). When installations fail, this type of current can produce highly dangerous arc flames. These arc flames are responsible for over 80% of all incidents caused by electrical faults. And when water from the firefighter hoses comes into contact with an installation on fire, the consequences can be catastrophic.

When fire hits a building equipped with a photovoltaic installation, firefighters are immediately in an extremely dangerous situation. And with the recent increase in the number of installations, firefighters are more often exposed to this danger.

For firefighters to do their jobs safely and successfully, photovoltaic installations have to be shut down quickly and completely. In the past there hasn't been an effective answer to this problem. Now there is.

With over 50 years' experience developing, producing and maintaining both AC and DC switchgear from 16 to 1000 amperes, Santon has proven itself to be one of the market's best suppliers. The Santon DC Switch's prime feature is its extremely short switching time of approximately 3 milliseconds which reduces the arc flame to a minimum and increases durability and safety. Our solutions are often used in situations where standard switches are ineffective or have to be adapted to meet customer requirements.

The Emergency Switch has been especially developed by Santon for the solar market. It's the first switch to guarantee firefighter safety during a fire in or around photovoltaic installations. The Emergency Switch is available

in several configurations designed to meet a range of demands in different circumstances. From small installations used for homes to large-scale commercial and industrial installations.

With our own in-house development department Santon is equipped to meet the most complex challenges. The Emergency Switch is one of our latest examples. Over the years, the demand for a solution to the specific problems faced by firefighters has increased and Santon has answered it with the Emergency Switch.

The solar market, the techniques used and the number of installations will evolve. Santon is committed to evolving as well by following these developments and continuing to develop and optimize solutions to maximize firefighter safety.

DIFFERENT SITUATIONS REQUIRE DIFFERENT APPROACHES. SANTON HAS DEVELOPED A RANGE OF EMERGENCY SWITCH SOLUTIONS TO MEET DEMANDS FOR SAFETY AND CONVENIENCE IN SMALL INSTALLATIONS FOR HOME USE AND IN LARGE COMMERCIAL AND INDUSTRIAL INSTALLATIONS. ALL THE SANTON SOLUTIONS ARE DESIGNED TO MEET REQUIREMENTS IN THE MOST DIFFICULT CIRCUMSTANCES, TO SAFELY ELIMINATE THREATS TO PEOPLE AND PROPERTY.

SANTON'S PERSPECTIVE

Although Santon has both motor-driven and pre-tensioned solutions in house, we prefer motor-driven solutions. Since emergency switches must be as close to photovoltaic panels as possible, they are often located in difficult-to-reach places like the roof of a building. Emergency systems have to be checked regularly. As a result, after every function check all emergency switches have to be reset manually at the switch itself. The extra convenience of remote resetting, combined with the fact that electric motors are relatively inexpensive nowadays, makes motordriven emergency switches a logical choice.

EMERGENCY SWITCH SOLUTIONS

Our range of emergency switches consists of solutions that can shut down photovoltaic installations quickly and completely with one simple action. At the heart of this solution is a motor-driven switch which is connected to a control panel located in an easily accessible position in the building. The control panel has just two buttons for either turning the installation on or off, and a status indicator showing information about the installation. The control panel turns off the entire installation which gives firefighters maximum security and insight in fire situations. Once the installation has been turned off, the only way to activate the

photovoltaic system again is by using the security key. This security key is an extra precaution to guarantee safety. The control panel can have two big LEDs for all emergency switches or separate LEDs for each individual switch.



The Emergency Switch



Fire alarm button

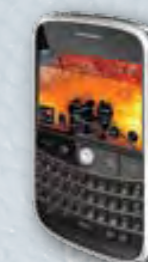

Mobile Phone



Operating panel with switch position indication

CONNECTION TO FIRE ALARM SYSTEM

By law every large building must have a fire alarm system. The emergency switch can easily be connected to a fire alarm system resulting in one safe, integrated solution for protecting a building. If a fire or other threat occurs anywhere in the building and the fire alarm is activated, the control panel sends a signal to the switch which shuts down the photovoltaic system.

MOBILE PHONE OPERATION

To minimize reaction time and maximize safety and convenience, remote operation of the photovoltaic system can be invaluable. A smart communication interface enables the emergency switch to be operated remotely using a mobile phone. This makes it possible for designated people to operate the entire installation from a distance.

INFORMATION LOGGING

The installation can be operated by several people, with different devices and from different locations. All events in which the status of the photovoltaic system changes are automatically logged in an event log file. This file shows when and from where the emergency switches were operated, allowing future precautions to be taken if necessary.

EMERGENCY SWITCH

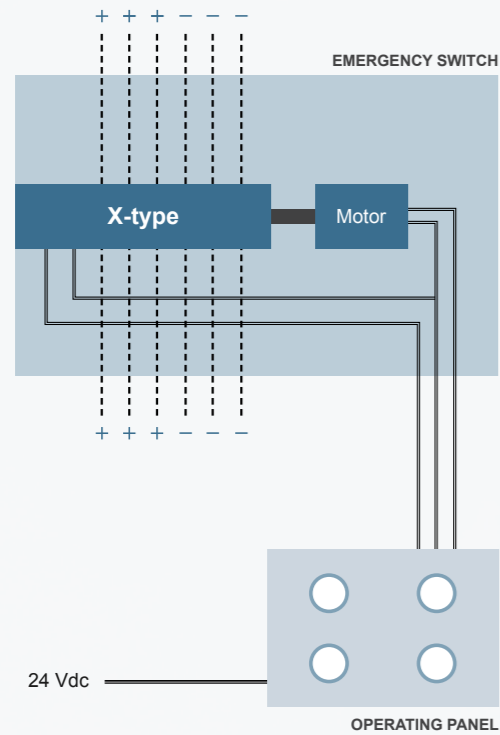

SOLUTION 1 Motor driven switch with analog cable connection

- Switches off when “emergency out” button is pressed
- Can be reset using remote control panel - after periodic function check of emergency system or after (false) alarm.
- Consumes no power when not in operation
- Stays in position when mains power fails
- One core cable provides easy feedback signal for switch position
- Independent disconnection of strings

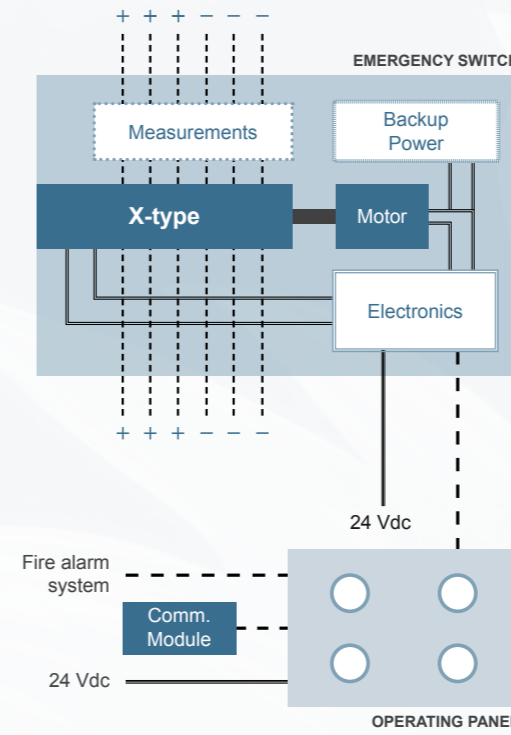

SOLUTION 3 & 4 Motor driven switch with bus connection to operating panel

- As solution 2 with motor-driven switch disconnect
- Independent disconnection of strings
- With bus connection for communication between operating panel and switch box(es)
- Optional mobile phone module for activation and sending feedback information to pre-selected telephone numbers
- Optional PV system fault detection and turning multipole switch to safe mode depending on system fault (e.g. serial & parallel earth faults)

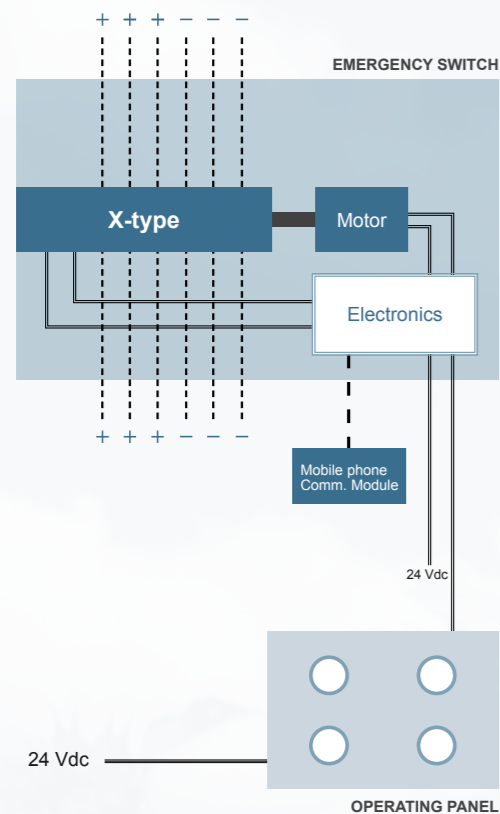

SOLUTION 2 Motor driven switch activated by mobile phone signal

- Activate switch-off by mobile phone using mobile phone module for sending feedback information to and from pre-selected telephone numbers
- Can also be activated by fire department itself
- Can be reset remotely - after periodic function check of emergency system or after (false) alarm
- Consumes no power when not in operation
- Stays in position when mains power fails
- Independent disconnection of strings

Solution number	1	2	3	4
SWITCHGEAR SPECIFICATIONS				
Motor driven	✓	✓	✓	✓
Conventional cabling	✓	-	-	-
Bus cabling	-	✓	✓	✓
MANUAL SWITCH OPERATIONS				
Operating panel (OFF/ON)	✓	✓	✓	✓
Fire alarm system (OFF)	-	Option	Option	Option
Mobile phone (OFF)	-	✓	Option	Option
AUTOMATIC SWITCH OFF OPERATIONS				
Temperature	-	-	-	✓
Supply power failure	-	-	✓	✓
Communication failure	-	✓	✓	✓
Measurement analysis	-	-	✓	✓
Arcing analysis	-	-	-	✓
INFORMATION				
Event logging	-	✓	✓	✓
Data logging	-	-	-	✓

- Maximizing firefighter safety
- Specially designed for solar industry
- Independent string disconnection
- Different configurations for maximum safety
- For small and large installations
- For home and professional use
- Based on proven Santon Packet DC Switchgear
- Integration with fire alarm system
- Mobile phone operation
- Bus connection
- Emergency switches from 16Amp to 1.000Amp
- Cost-efficient solution



info@santonswitchgear.com, www.santonswitchgear.com, EN-ISO 9001

